



Le Hoang Nguyen for BRASS collaboration.

Institute of Experimental Physics - University of Hamburg

le.hoang.nguyen@uni-hamburg.de

Development, Calibration and Current Status of the BRASS-p Experiment

Contents:

1. Broadband dark matter search with dish antenna.
2. BRASS-p Setup
3. Hidden Photon Science Run and Preliminary Result.



Johannes Gutenberg in his workshop
Publisher: Encyclopædia Britannica

Broadband dark matter search with dish antenna.

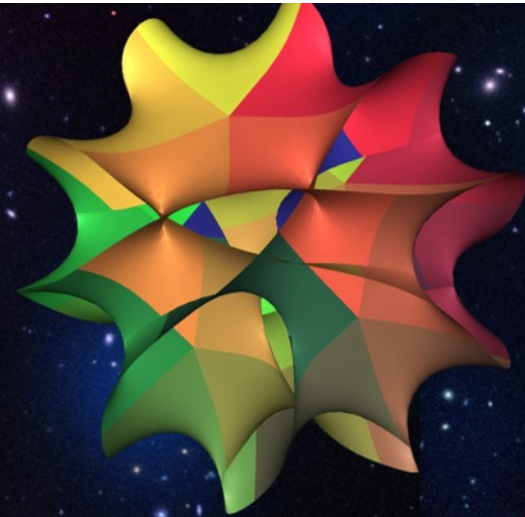

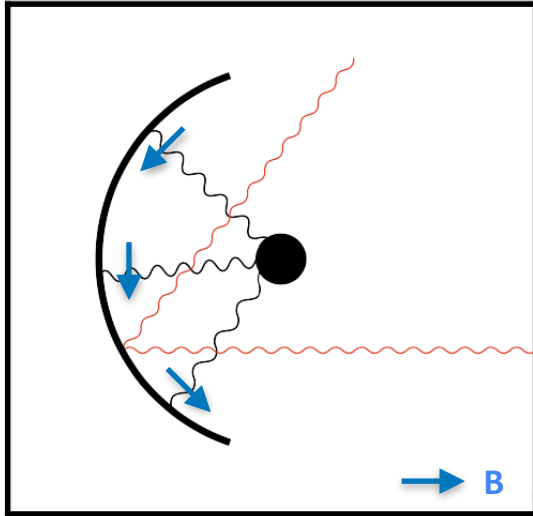

“Searching for WISPy Cold Dark Matter
with a Dish Antenna “

Hidden Photon

$$\chi_{\text{sens}} = 4.5 \times 10^{-14} \left(\frac{P_{\text{det}}}{10^{-23} \text{ W}} \right)^{\frac{1}{2}} \left(\frac{0.3 \text{ GeV/cm}^3}{\rho_{\text{CDM,halo}}} \right)^{\frac{1}{2}} \left(\frac{1 \text{ m}^2}{A_{\text{dish}}} \right)^{\frac{1}{2}} \left(\frac{\sqrt{2/3}}{\alpha} \right).$$

Axion/ALPs

$$g_{\phi\gamma\gamma, \text{sens}} = \frac{3.6 \times 10^{-8}}{\text{GeV}} \left(\frac{5 \text{ T}}{\sqrt{\langle |\mathbf{B}_{\parallel}|^2 \rangle}} \right) \left(\frac{P_{\text{det}}}{10^{-23} \text{ W}} \right)^{\frac{1}{2}} \left(\frac{m_{\phi}}{\text{eV}} \right) \left(\frac{0.3 \text{ GeV/cm}^3}{\rho_{\text{DM,halo}}} \right)^{\frac{1}{2}} \left(\frac{1 \text{ m}^2}{A_{\text{dish}}} \right)^{\frac{1}{2}}$$

Stefan (talk on Wed) and Osamu (talk on Thurs) 🙏

- **Broadband sensitivity to a large parameter space and resonant enhancement is compensated by the large surface area.**
- **Broadband Radiometric Axion Searches (BRASS)**
 - A parabolic mirror
 - Flat conversion panels (with permanent magnets)
 - Broadband antenna and digital backend to process the signal.

- **Broadband sensitivity to a large parameter space and resonant enhancement is compensated by the large surface area.**
- **Broadband Radiometric Axion Searches (BRASS)**
 - A parabolic mirror
 - Flat conversion panels (with permanent magnets)
 - Broadband antenna and digital backend to process the signal.

Prototype: BRASS-p

BRASS-p Setup



BRASS-p Setup

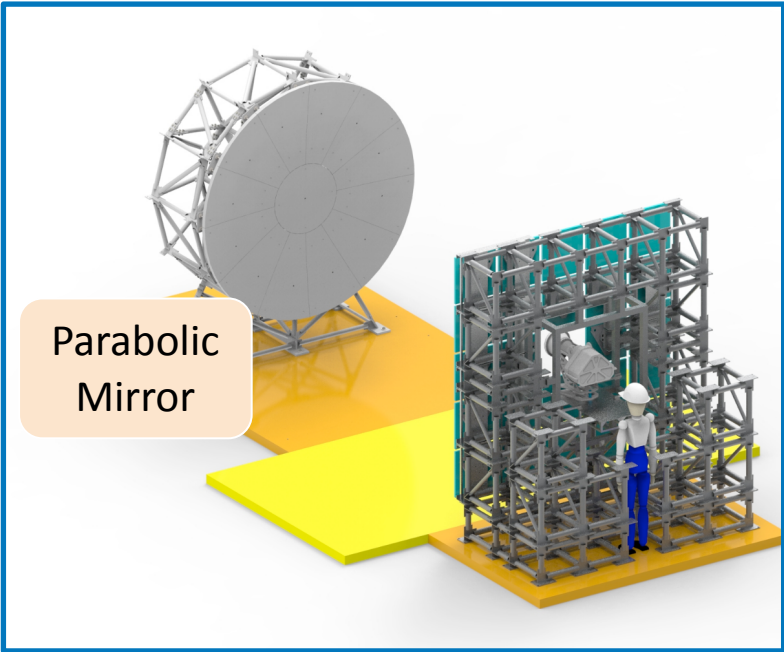

Parabolic
Mirror

A 3D rendering of the BRASS-p setup. On the left is a large, grey, parabolic mirror mounted on a yellow base. To its right is a complex, grey, spherical metal frame structure. A small figure of a person in a white hard hat and blue overalls stands next to the frame for scale. The entire setup is on a yellow platform.

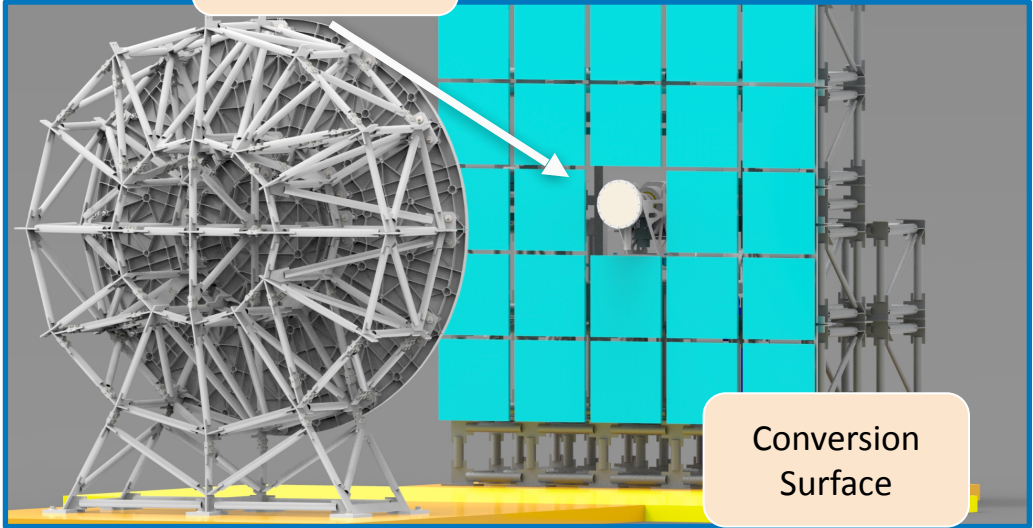

Broadband
Receiver

A close-up 3D rendering of the BRASS-p setup. The large, grey, spherical metal frame structure is shown in detail. A white arrow points from a label to a small, white, circular component mounted on the frame. To the right of the frame is a large, cyan-colored grid structure. The entire setup is on a yellow platform.

Conversion
Surface



Conversion Panel
 (24 x 0.25m²)



Parabolic Mirror

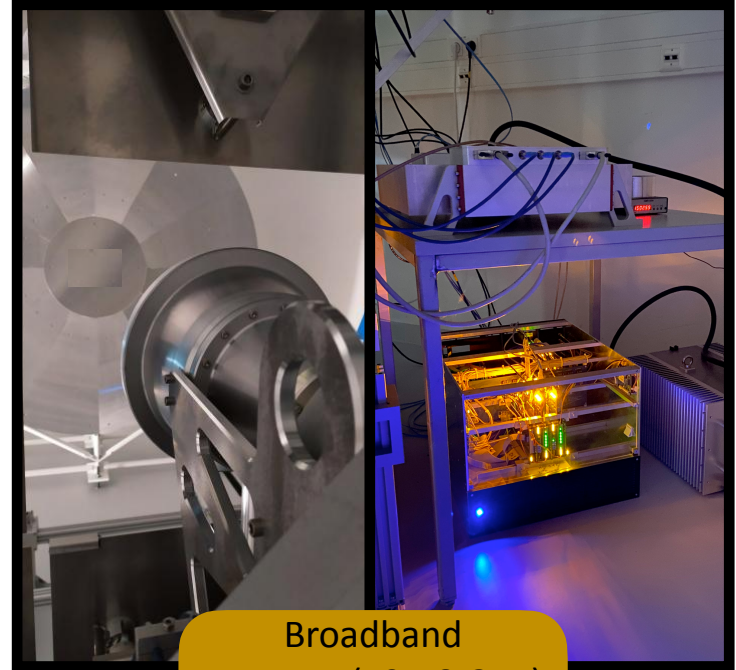

Broadband
 Antenna (12-18 GHz)
 and 8 GS/S Digitizer

Parabolic Mirror

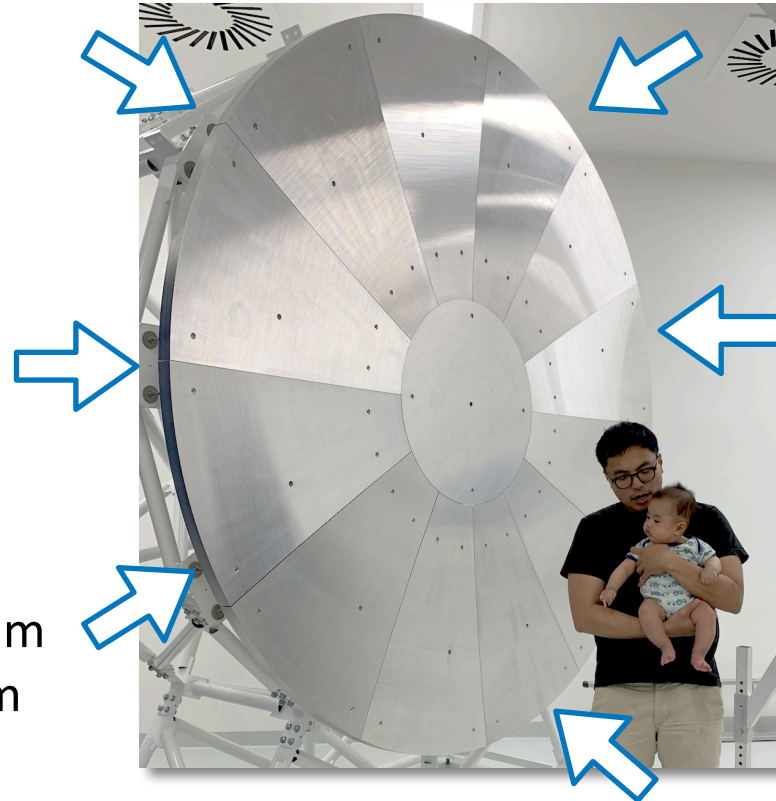

$d = 2.5\text{m}$
 $f = 4.8\text{m}$

Conversion Panels

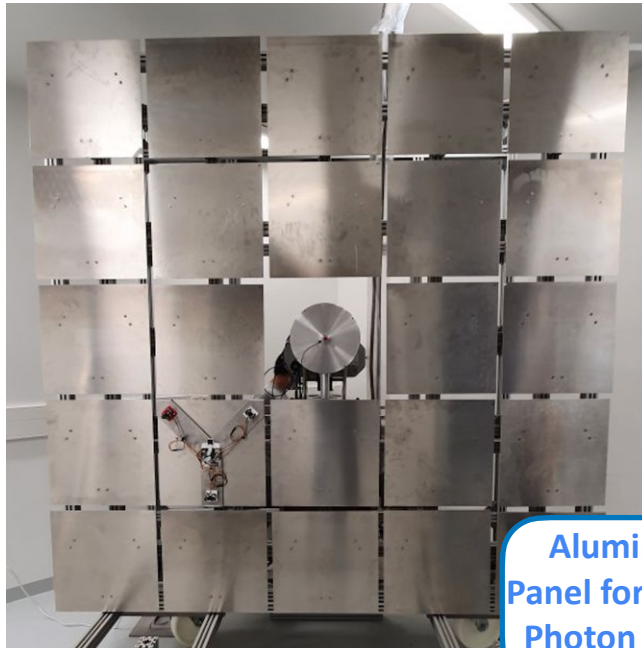

Aluminium Panel for Hidden Photon Search

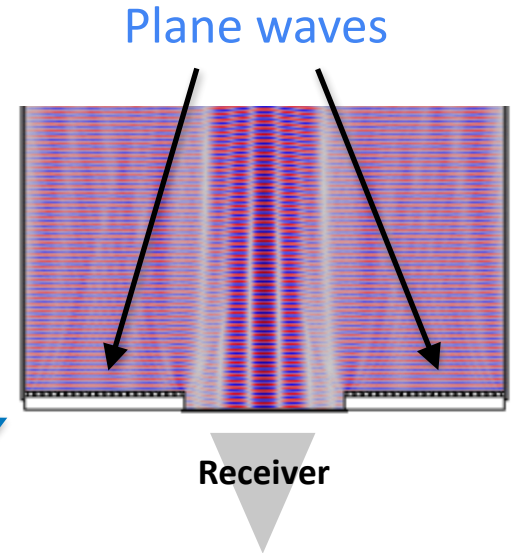
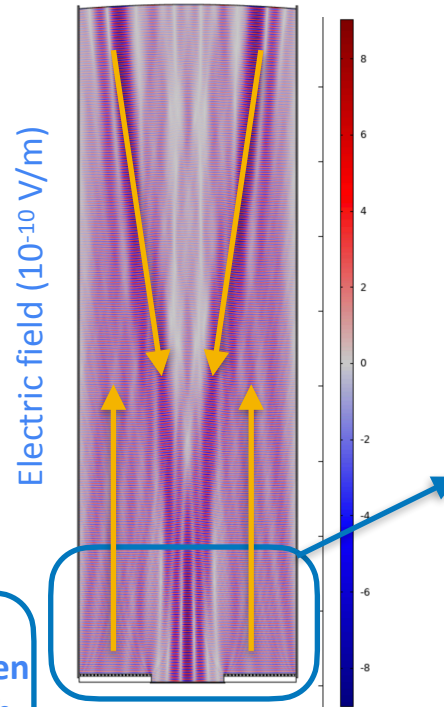

👉 Johannes Ulrichs blitz talk and poster on Monday

Permanent Magnet Panel for Axion/ALPs Search

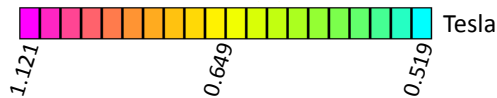
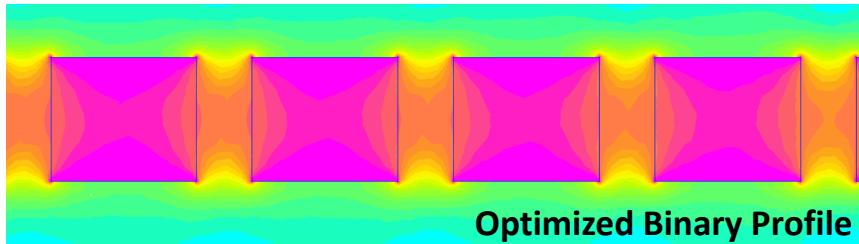
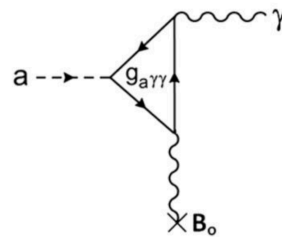
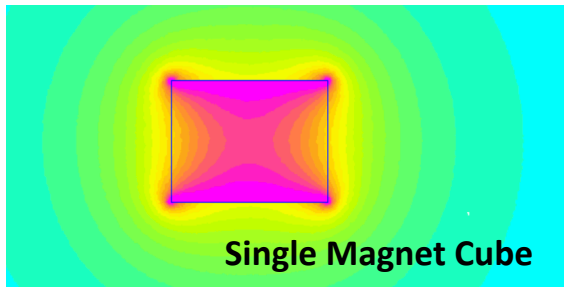

Averaged horizontal field strength is approx 0.9 Tesla

Converted Radiation Simulation

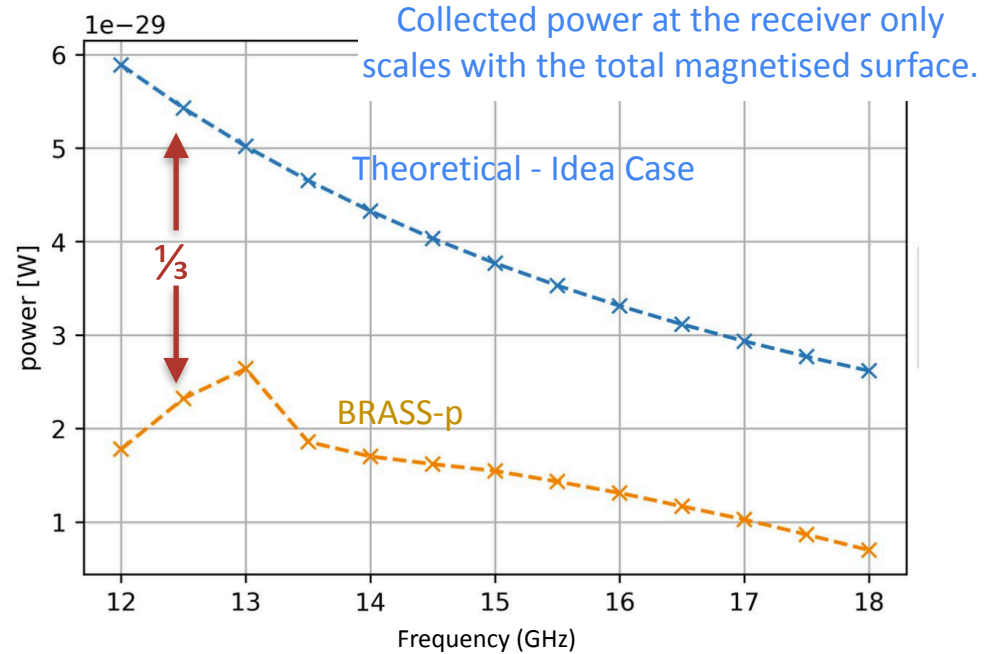
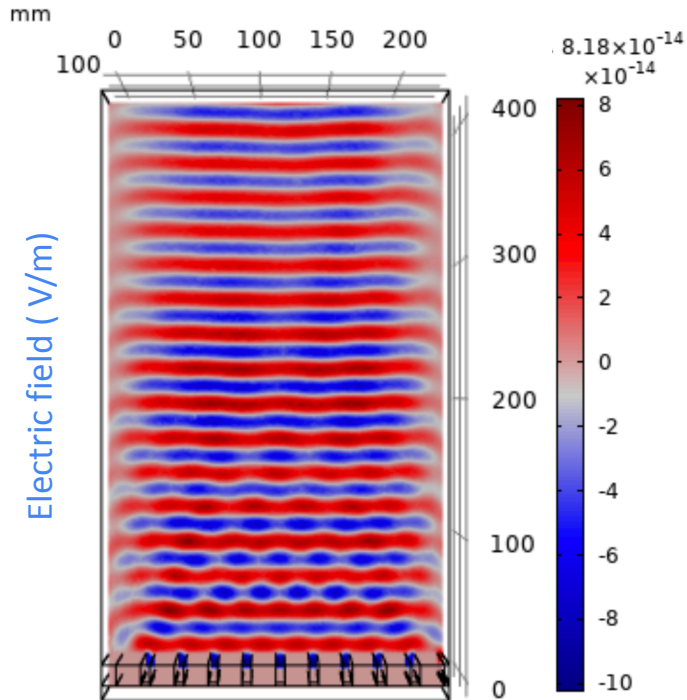

Analog Frontend and Digital Backend

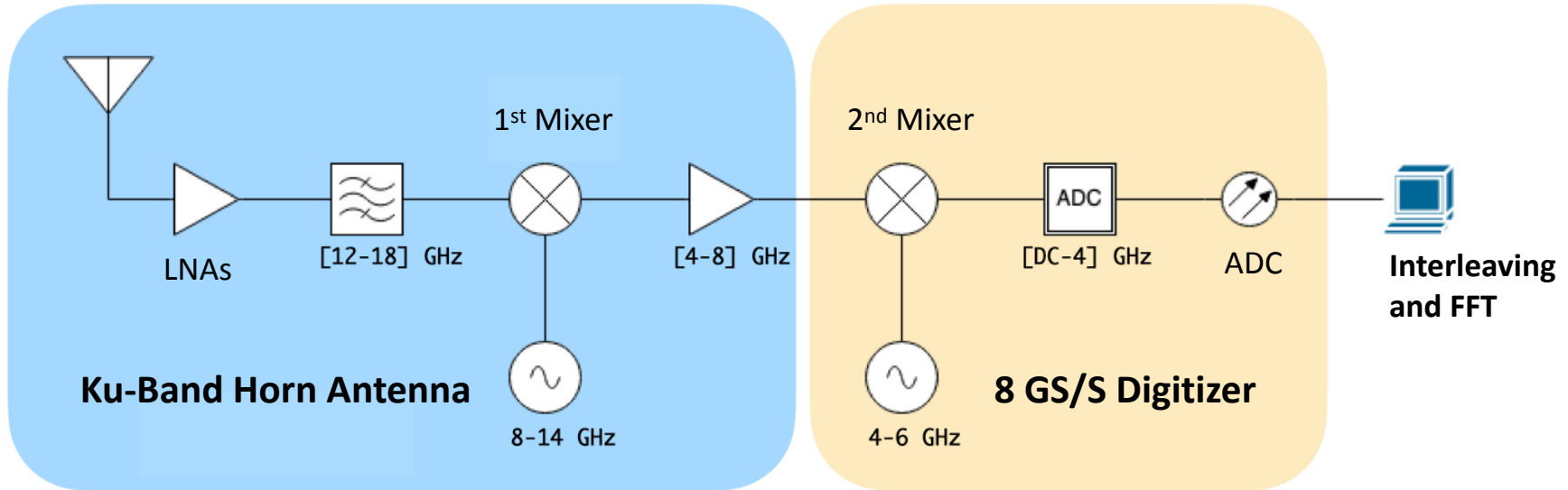

Analog Frontend: Ku-Band Horn Antenna

- Broadband receiver and first mixing stage from 12 to 18 GHz to IF 4-8 GHz.
- 3-LNA-chain with 1st stage operated at approx 10 K
- Two polarisation outputs for DM signal study/rejection.

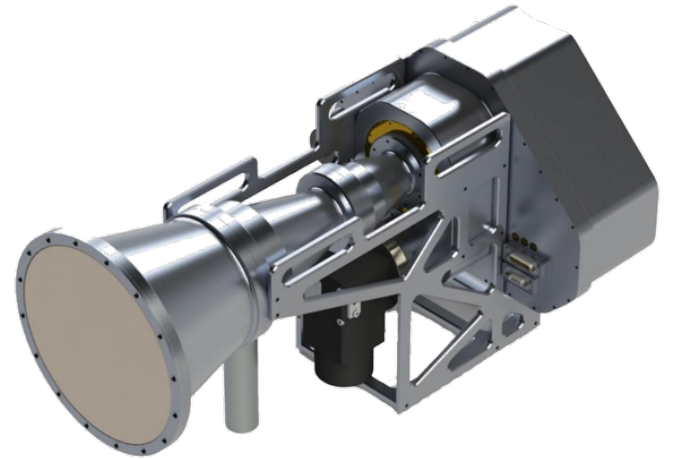

Receiver's System Temperature

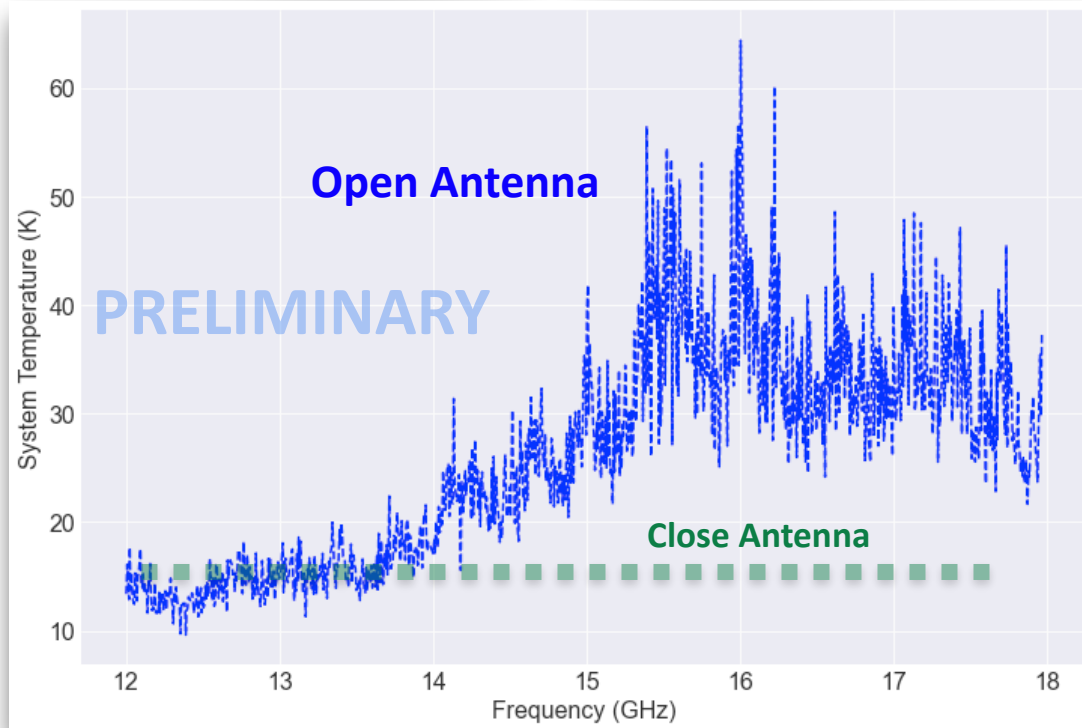

Digital Backend: 8 GS/S Processing



- Second mixing stage of the signal from the receiver output to a DC - 4 GHz IF range.
- 4 interleaved ADCs at 2 GSPS digitizing the IF signal.
- Data is transferred to the acquisition PC, followed by the interleaving and FFT (WISPDMMX's processing structure)
- GPU powered FFT produces high resolution (up to 25 Hz) with real-time post processing.

↪ 40% of dead time 🙄

First Science Run

The background of the slide is a cosmic scene with a dark blue and purple nebula. In the upper right, there is a complex 3D geometric structure composed of many small, colorful (yellow, red, orange, green) facets, resembling a star or a cluster of particles. In the lower left, there is a visualization of a particle detector or a data set, showing a blue, elongated shape with numerous lines radiating from a central point, colored in green, yellow, and red. The overall aesthetic is scientific and futuristic.

- First science run with conversion panel of **2 m²**
 - **Only sensitive to hidden photons since no magnets are installed yet**
 - Science run 1a in December: 53 hours, 12-16 GHz, resolution of 625 Hz
 - Science run 1b in March: 83 hours, 14-18 GHz, resolution of 625 Hz

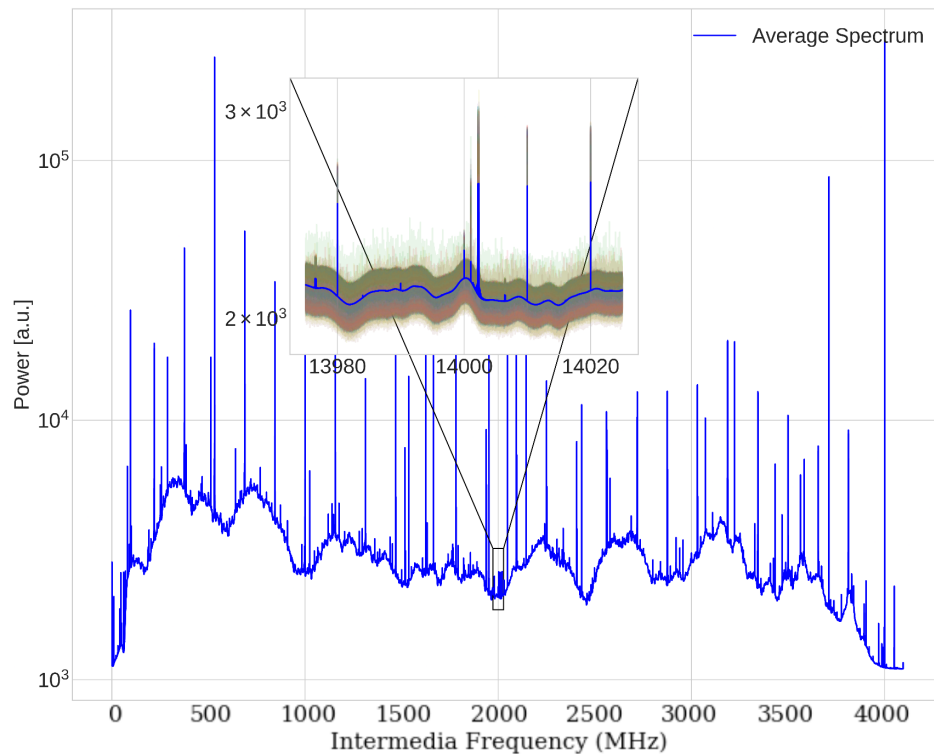

- Single spectrum is averaged from 20 second of data @ 625 Hz
- Science run 1a: 10000 single spectra
- Science run 1b: 15000 single spectra

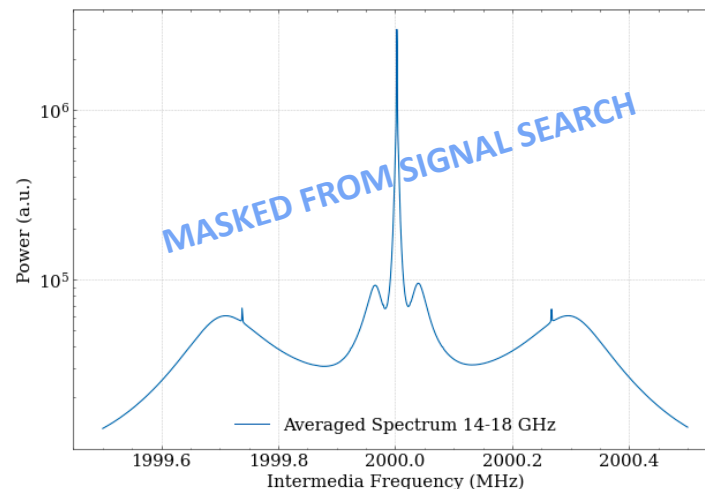

Scanning for signal - Moving 1 MHz ROI

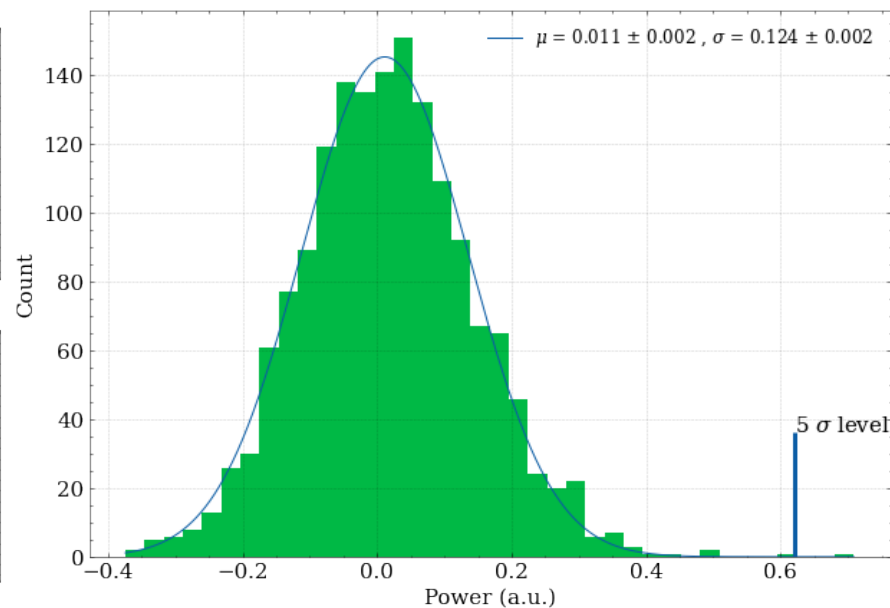
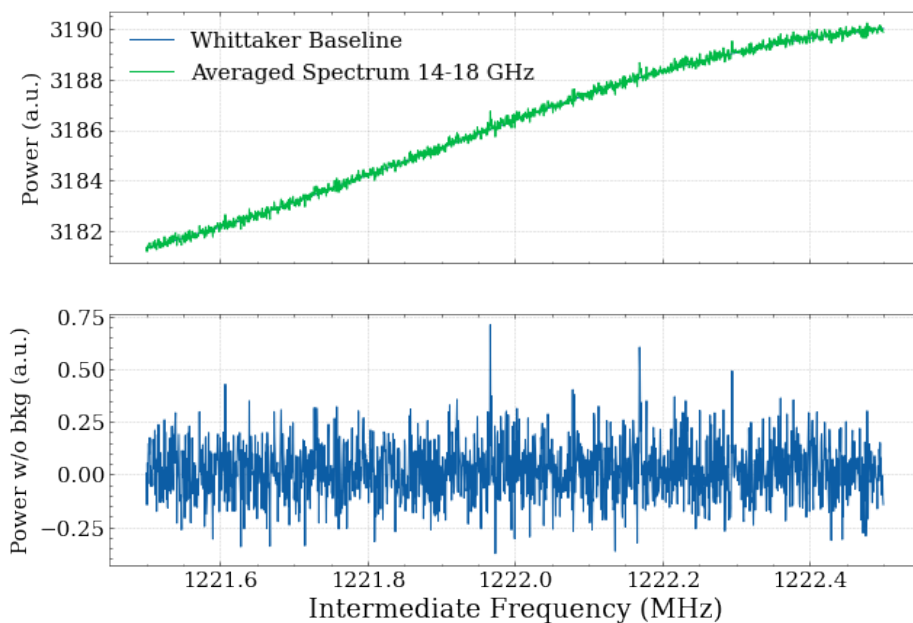

Scanning for signal - Moving 1 MHz ROI

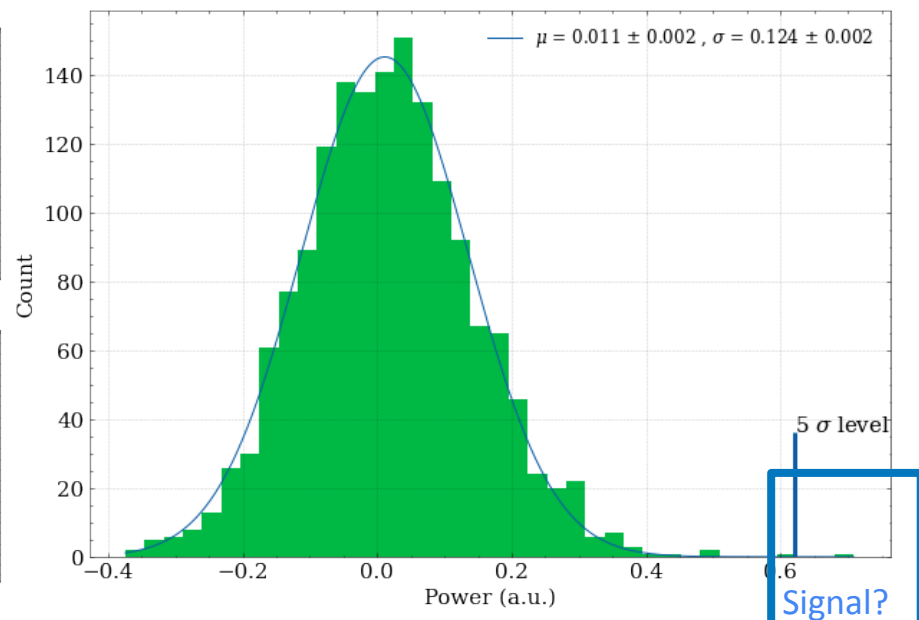
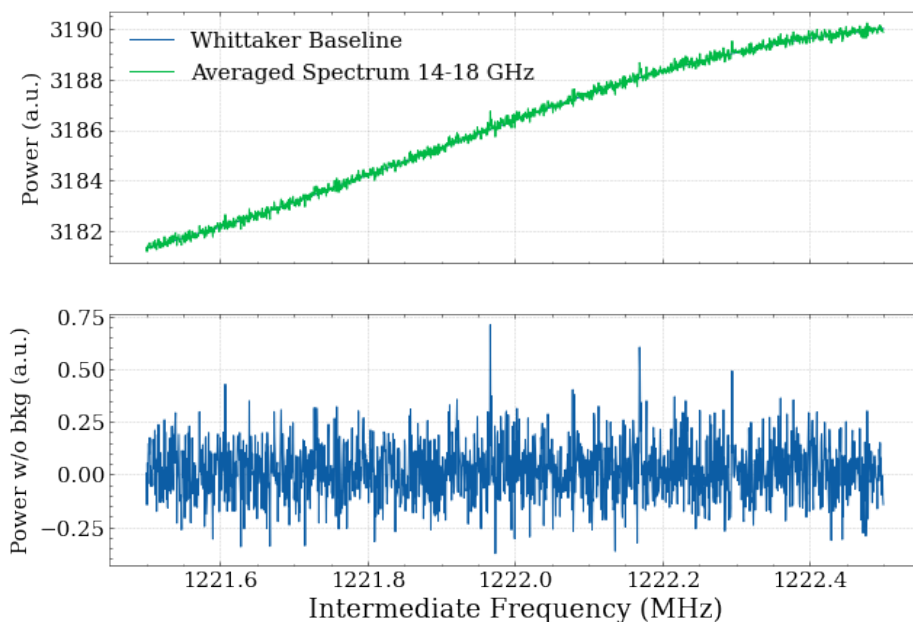

Signal Criteria

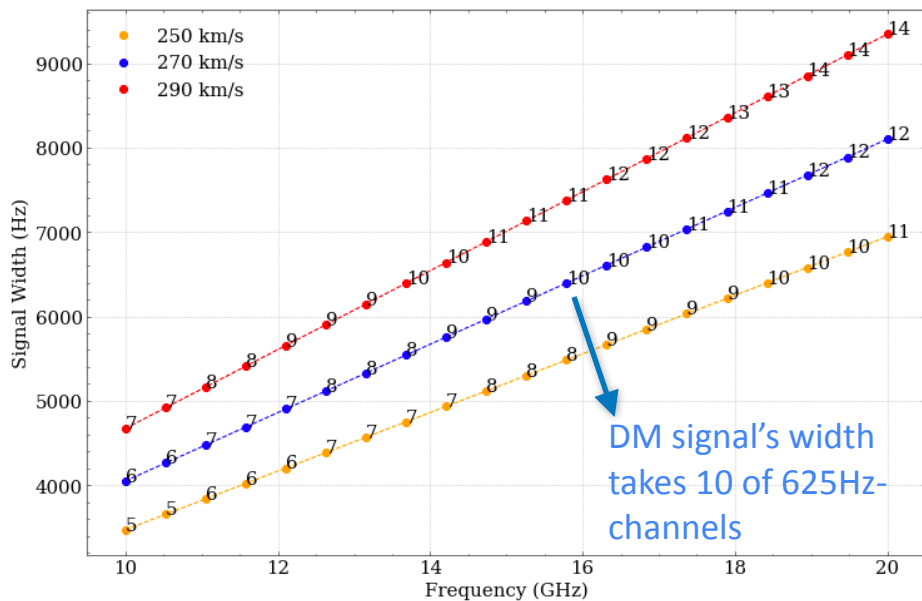

1. Matching signal width

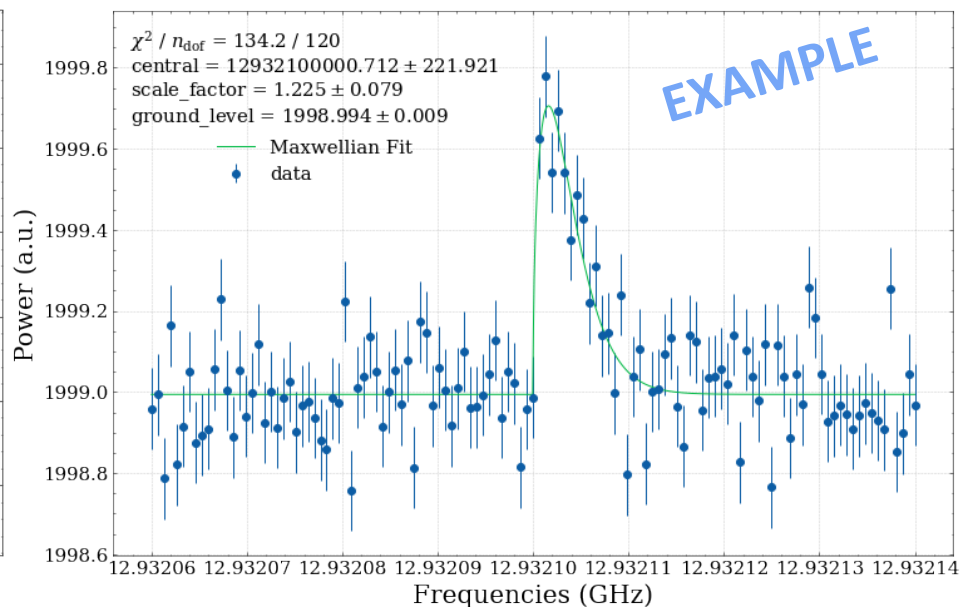

2. Matching Maxwellian profile

Result:

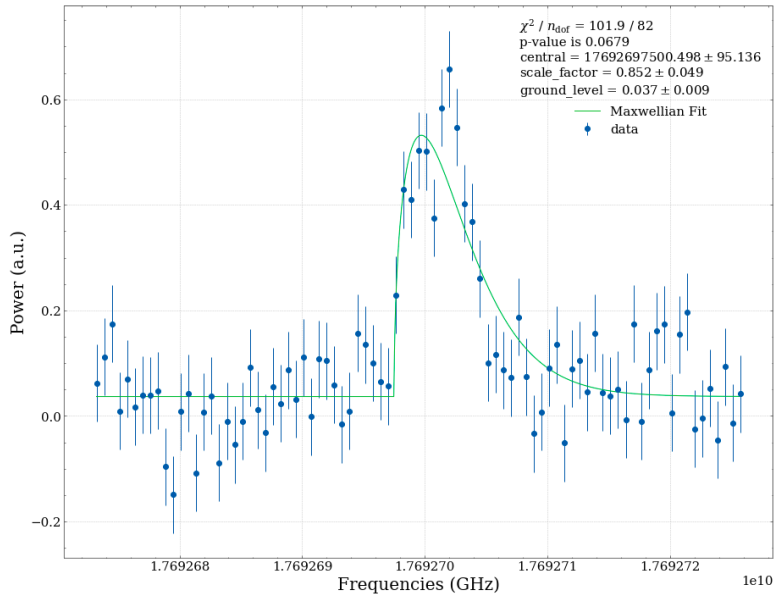

Result

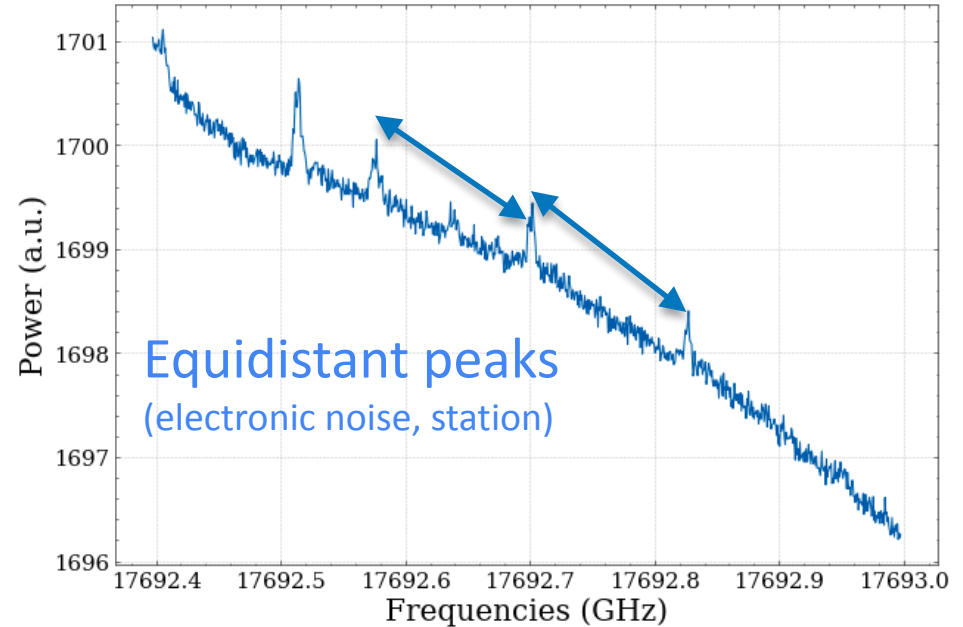
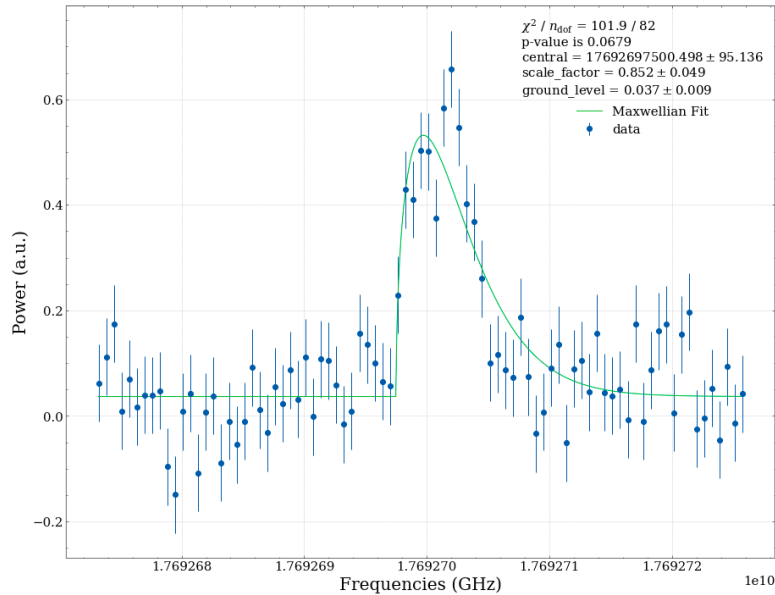

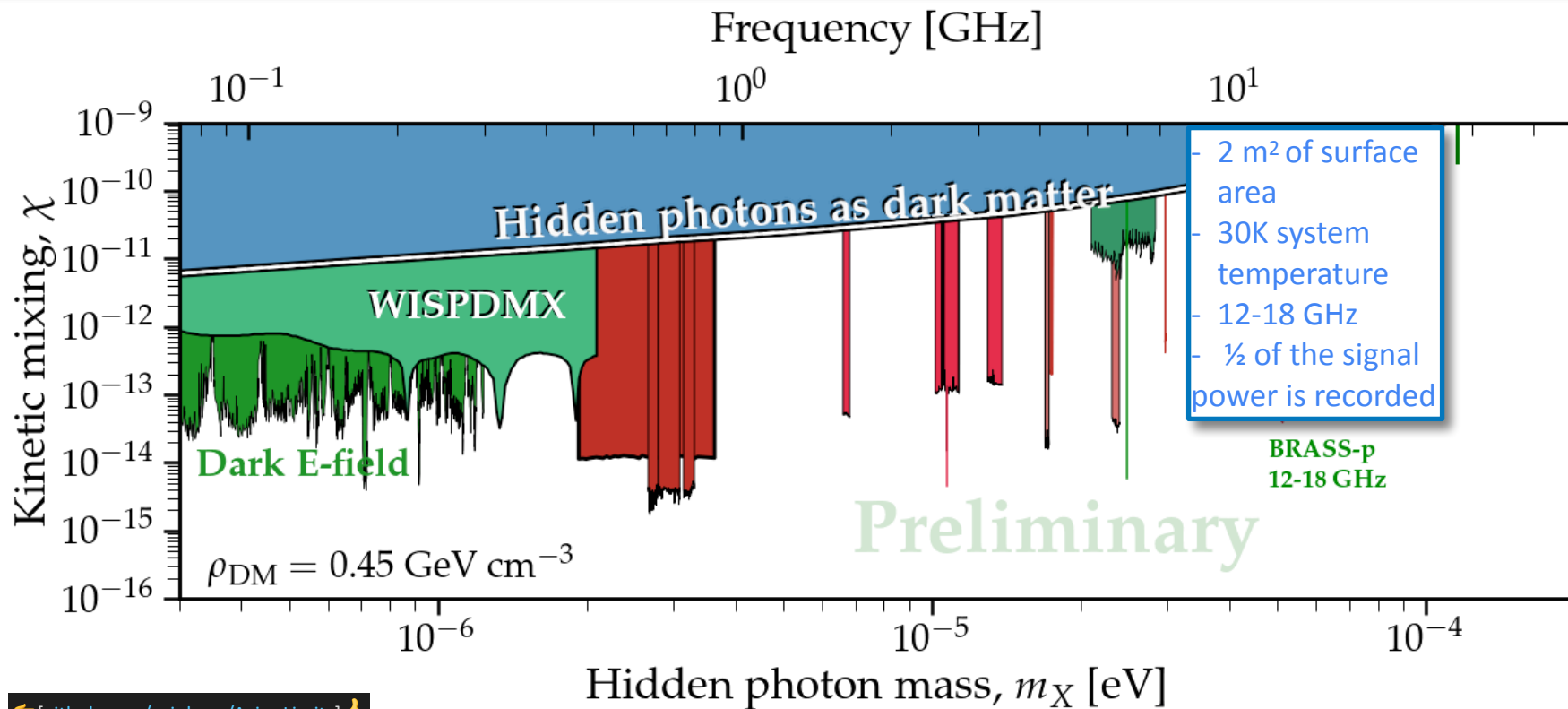

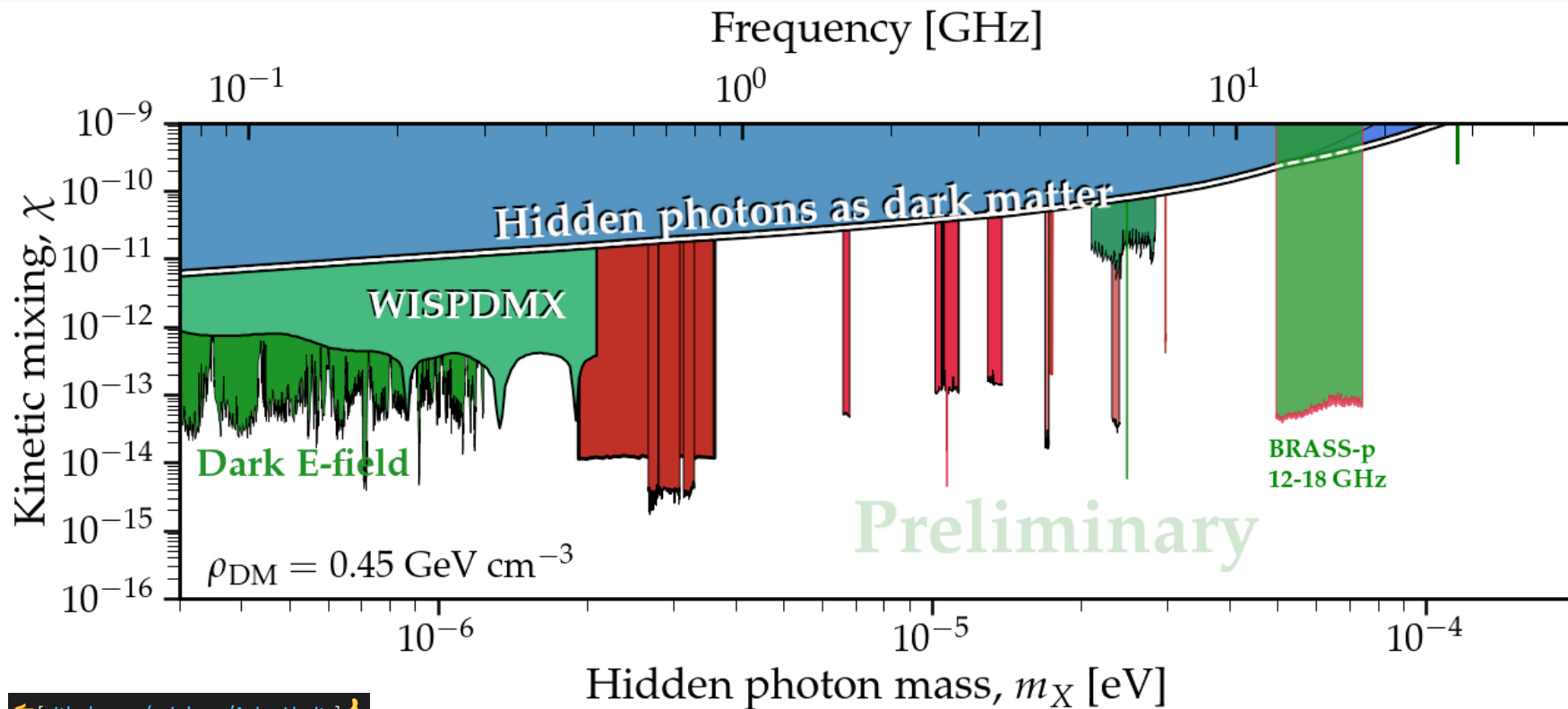

Future plans:

- Publication with technology roadmap and first result.
- Guided hidden photon search.
- Improved insulation.
- Axion with magnet panels.
- Seasonal modulation signal searches.
- BRASS-p is easily scalable (frequency, IF bandwidth, conversion surface, mirror).

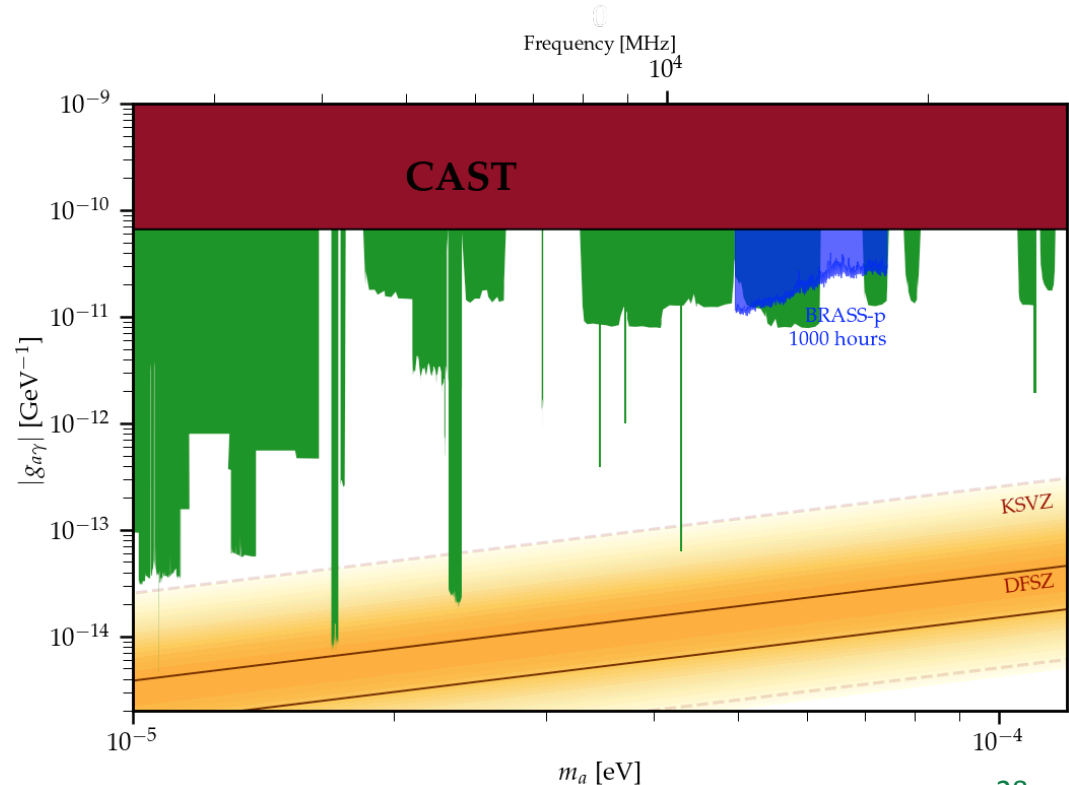

- BRASS-p is the implementation of the mature radio astronomy technology.
- The most powerful hidden photon dark matter telescope with leading sensitivity in the mass range.
- Unique design of the magnet panels for axion/alps search (with future upgrade) that drives down the cost of the experiment.
- A green experiment 🌱🌱🌱

Thank you for listening

Power distribution at the focal point/phase center

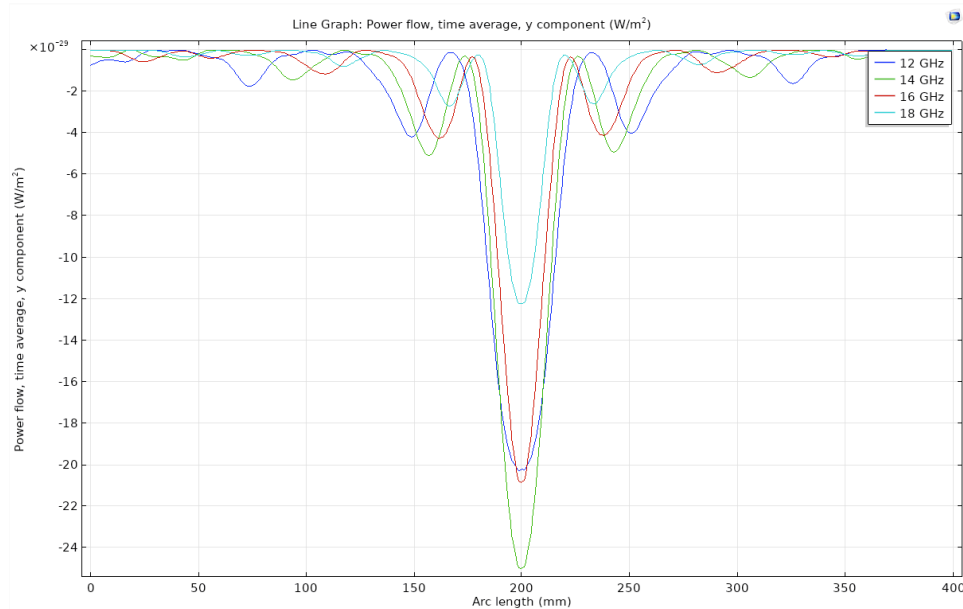

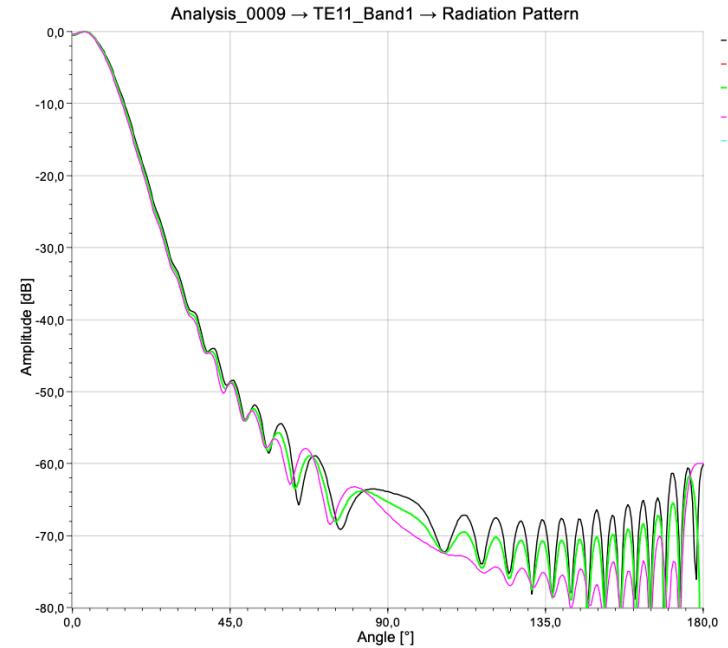
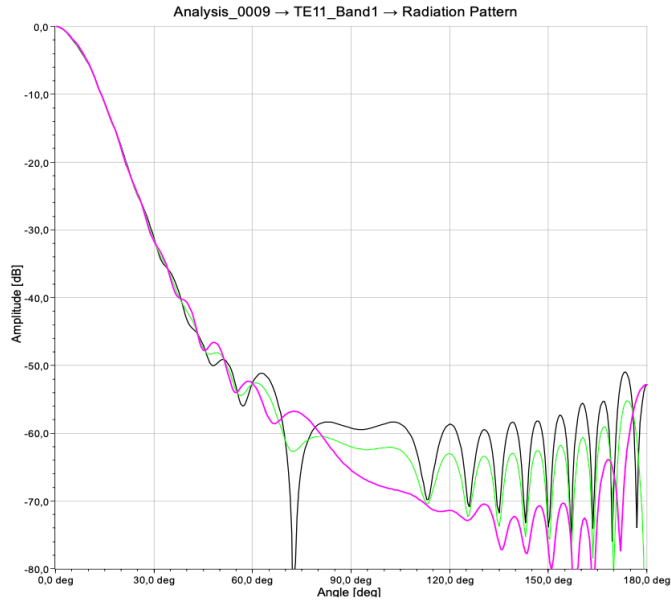

Radiation Pattern at 12 GHz and 15 GHz

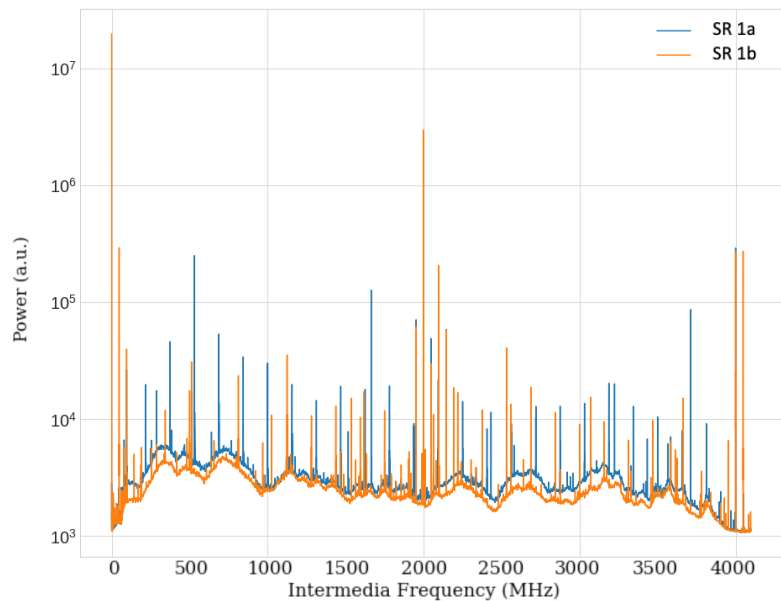

Broadband IF Spectrum

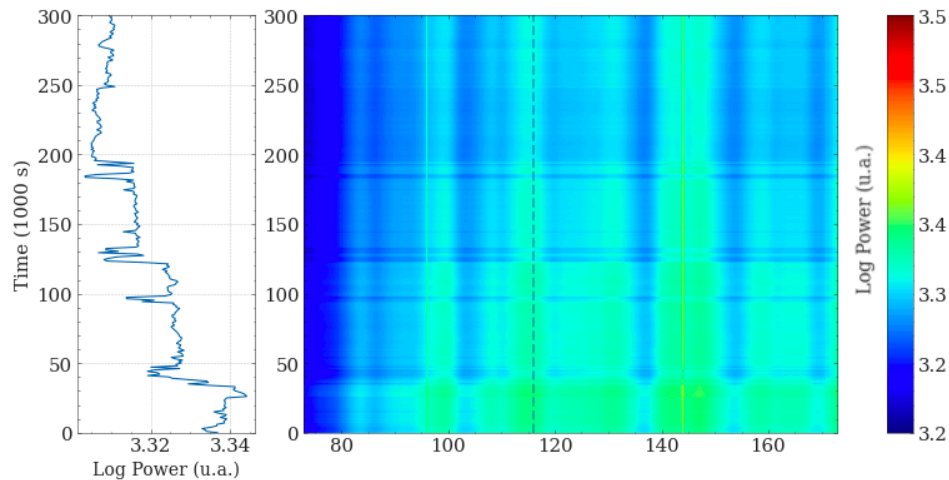

Waterfall Plot of SR 1b (70-190 MHz)

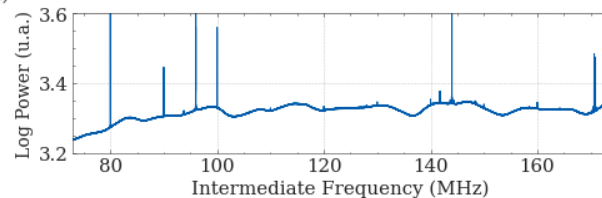

Conversion Panels



Aluminium
 Panel for Hidden
 Photon Search

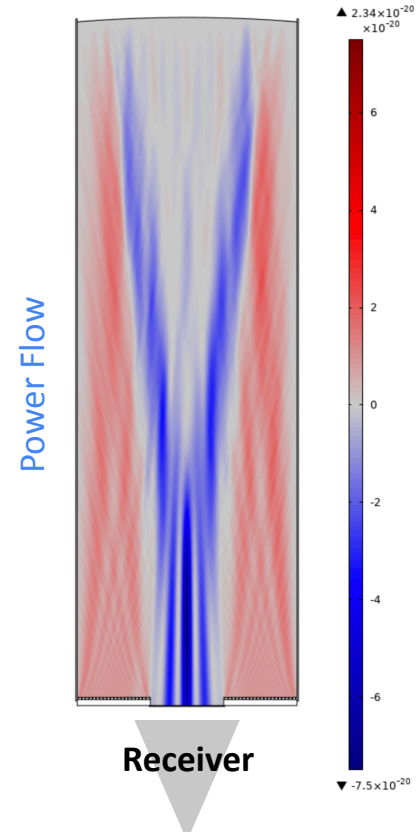

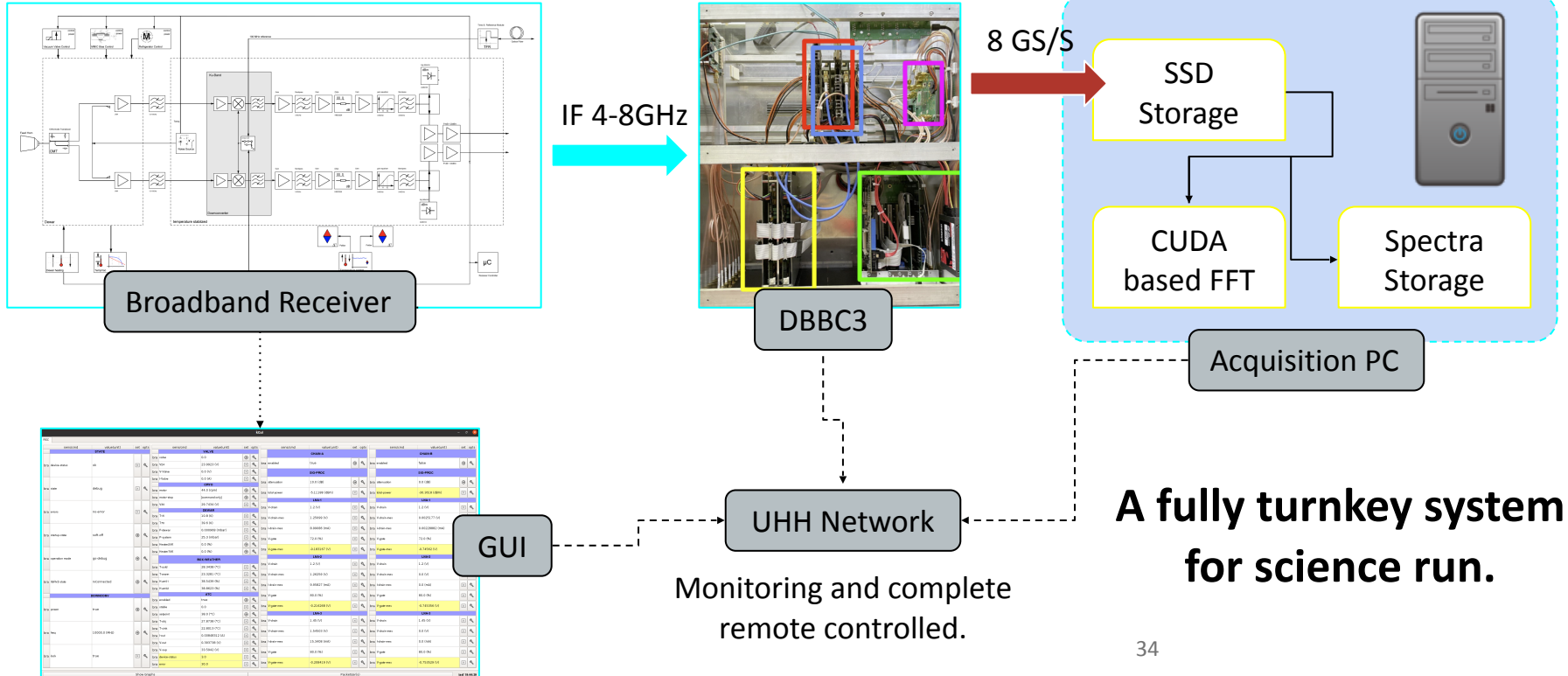

Digitizer and Postprocessing Calibration

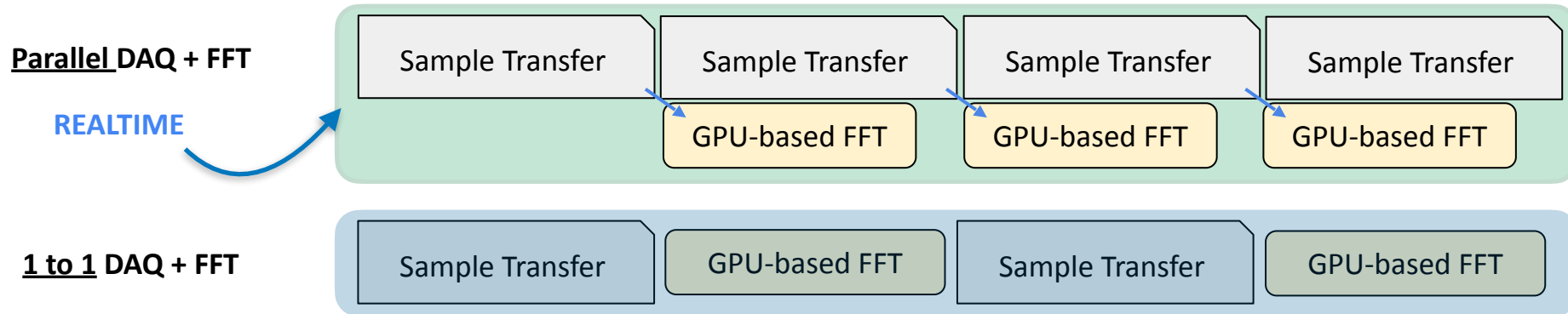

- Only one polarization is digitized by the DBBC3.
- Bottle neck: computational power, CPU cores, PCIe.
- For every 1000 DAQ, there is 2 DAQ with sample loss $> 0.5 \%$



Axion-Photon Coupling; Detection

$$P_{\text{SIG}} = \eta g_{a\gamma\gamma}^2 \left(\frac{\rho_a}{m_a} \right) B_0^2 V C Q_L$$

Where:

- $g_{a\gamma\gamma}$: axion coupling constant
- m_a : axion mass
- ρ_a : local density of axions in the halo
- B_0 : magnetic field strength
- V : volume of the cavity
- C : mode dependent form factor
- Q : cavity quality factor

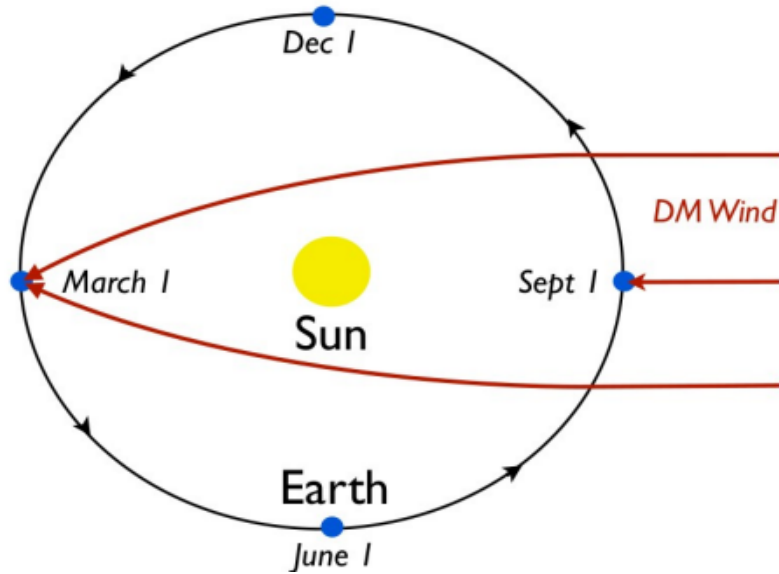

Lee et al. PRL 112 (2014)

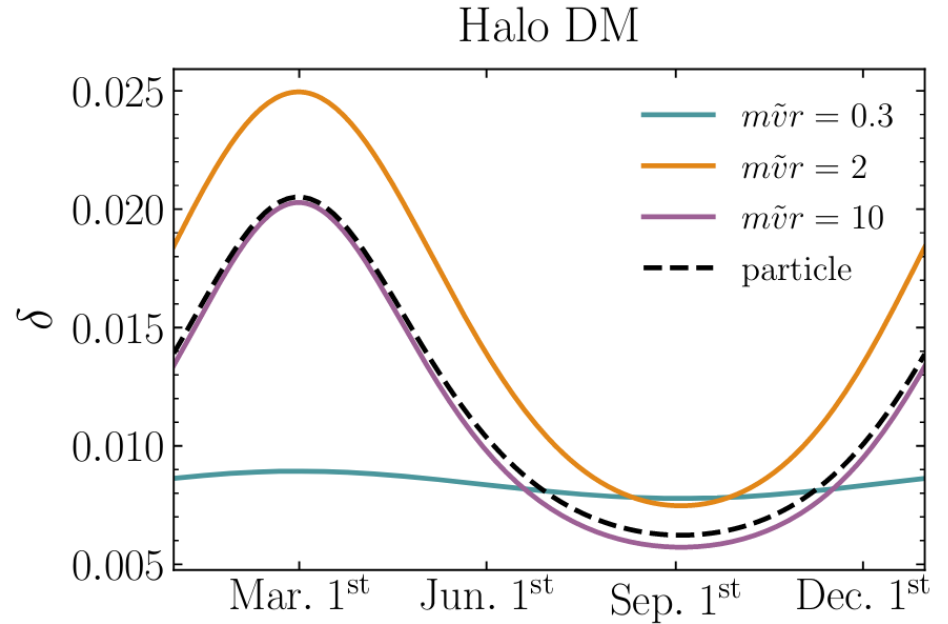

[Kim and Lenoci 2021](#)

Results/Radiation simulation 2D

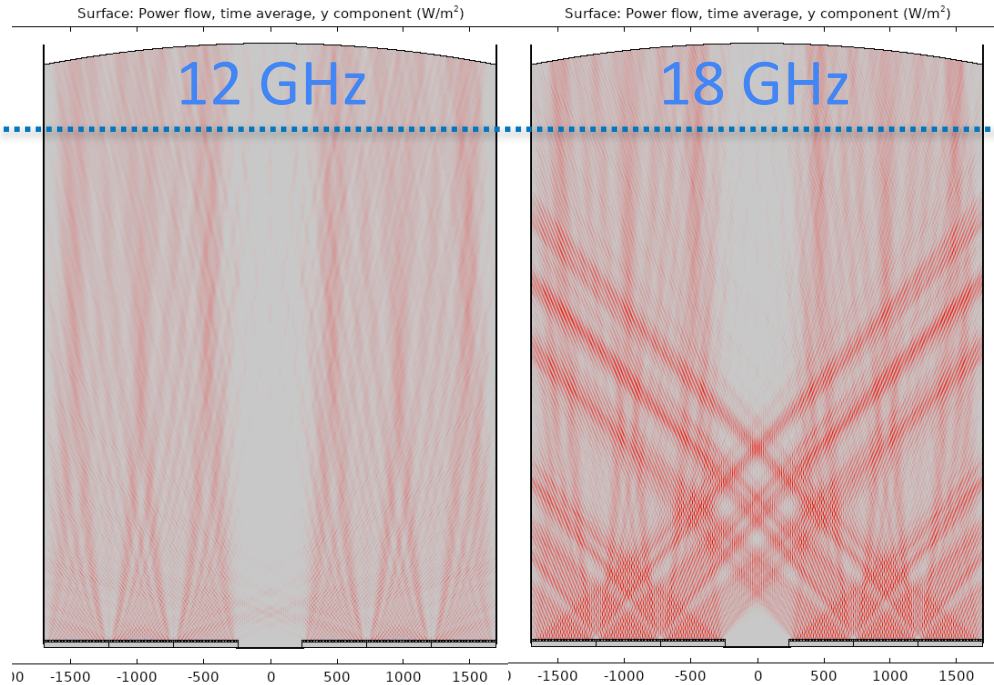

$$g_{\alpha\gamma\gamma} = 10^{-14} \text{ GeV}^{-1}$$

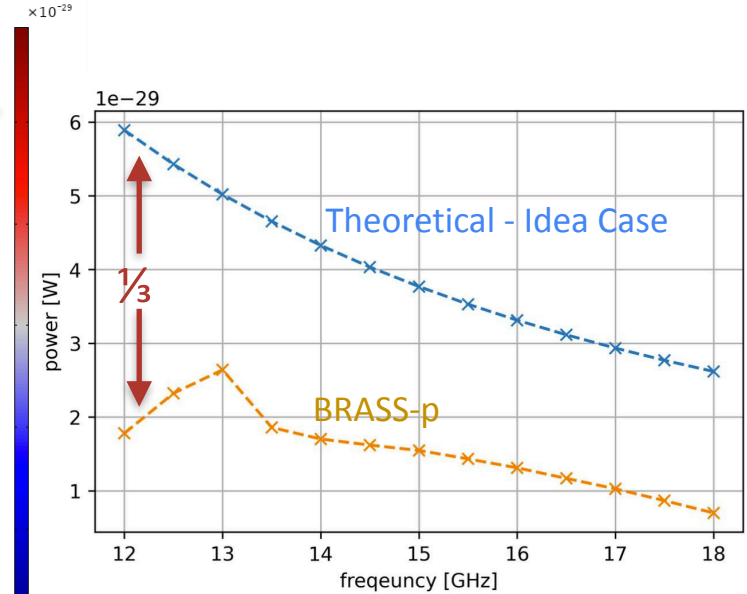

Position Calibration

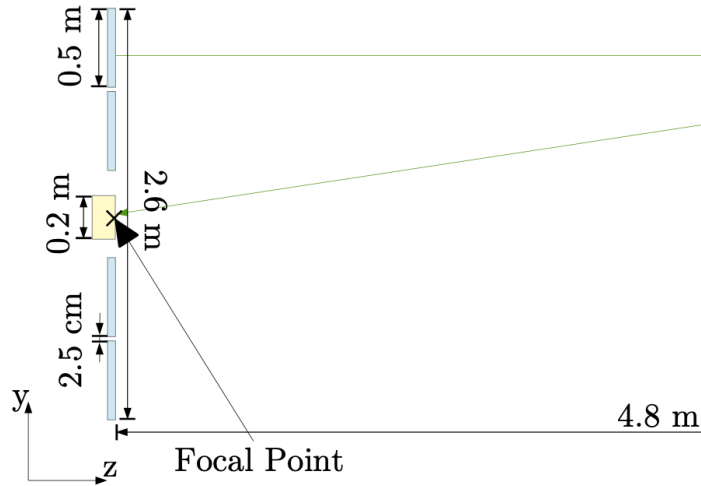

FIXED!

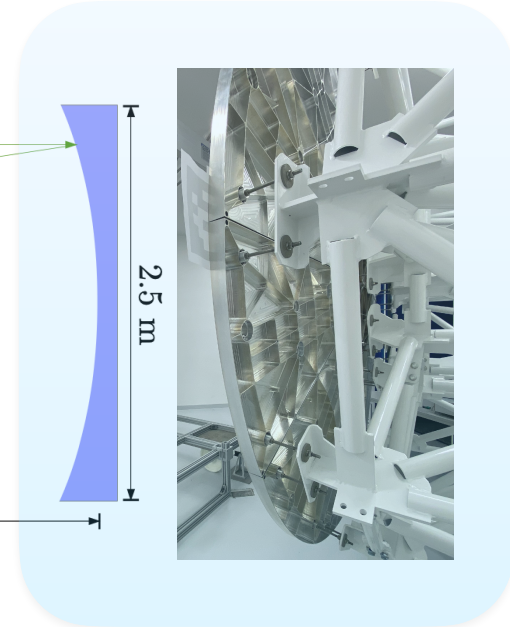

Position Calibration

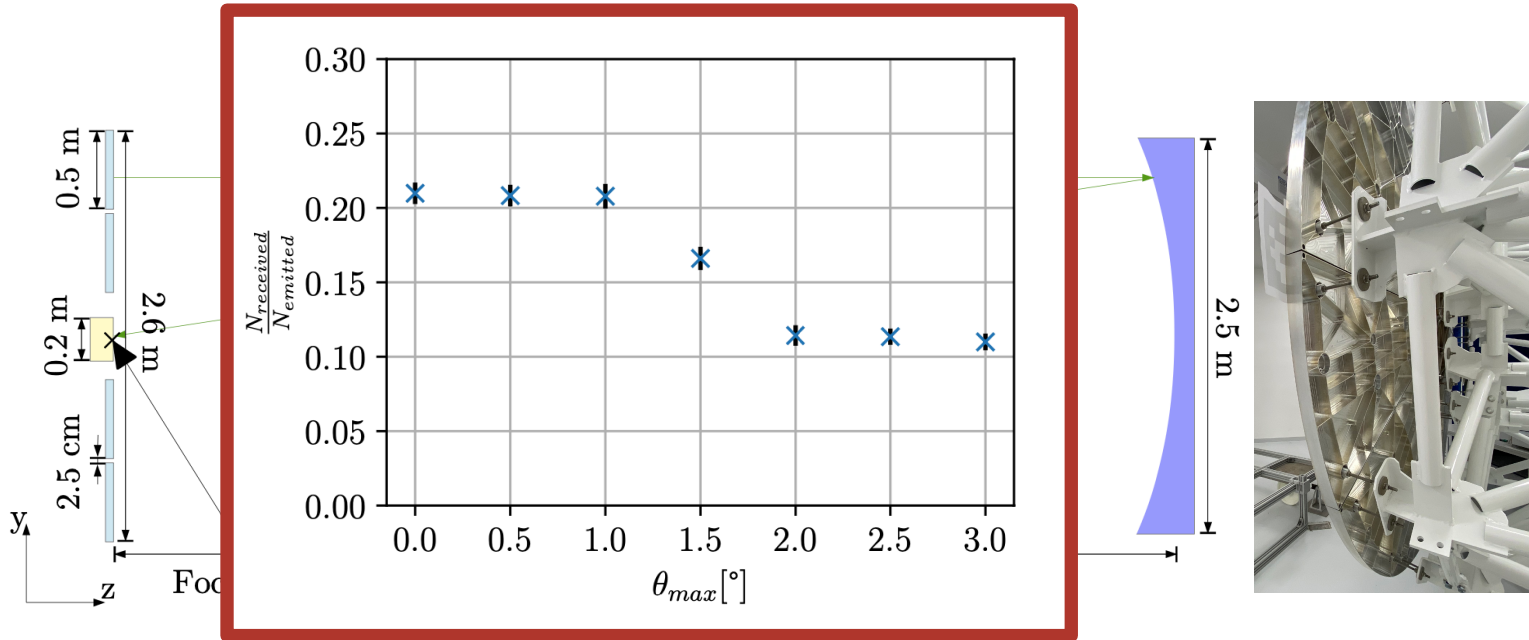



Laser LIDAR with approx 1 billion points at sub mm precision

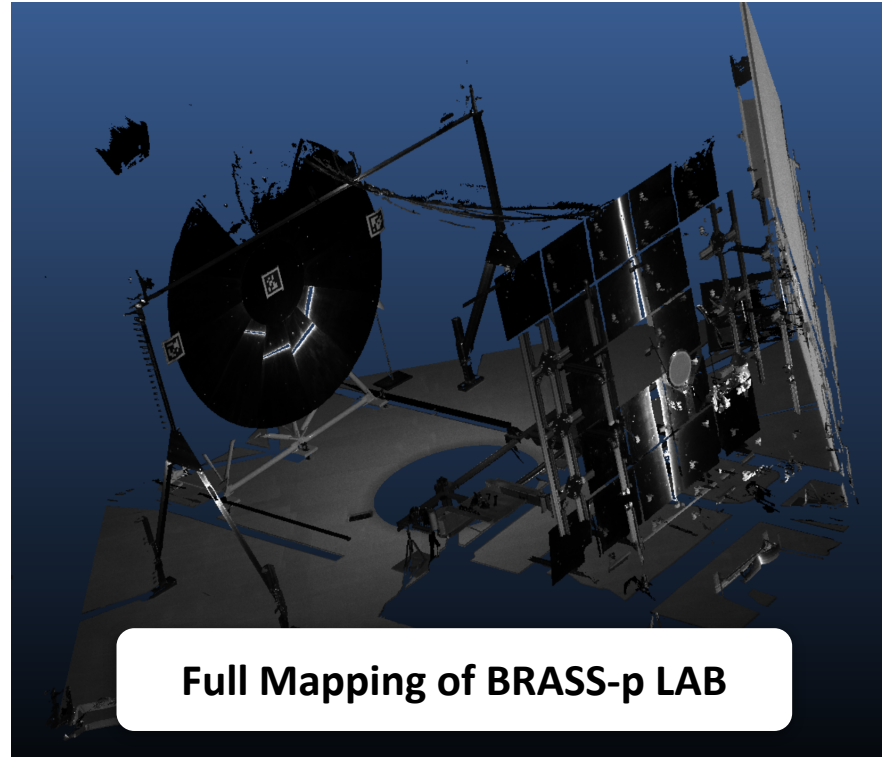

Full Mapping of BRASS-p LAB

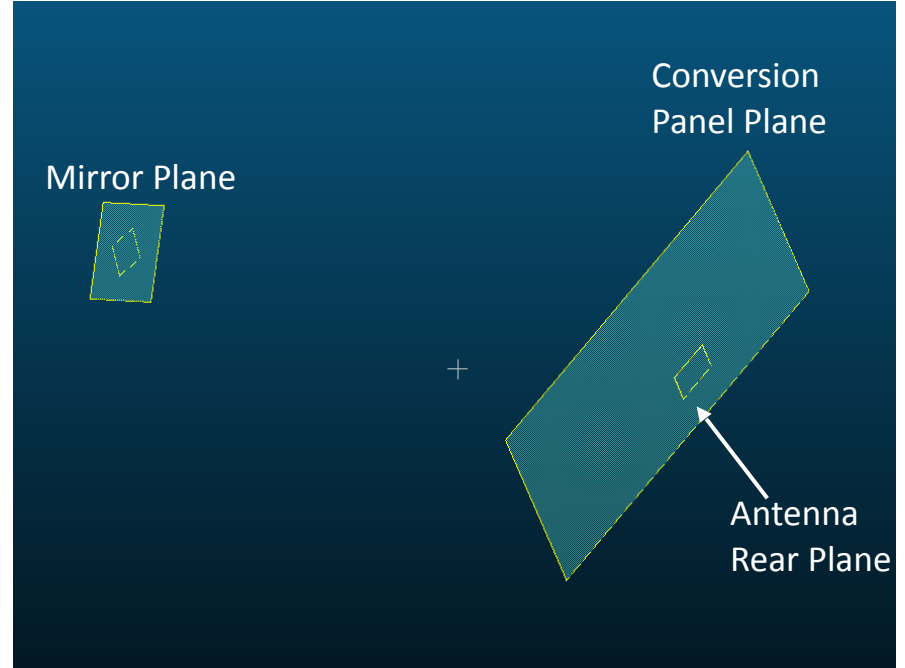
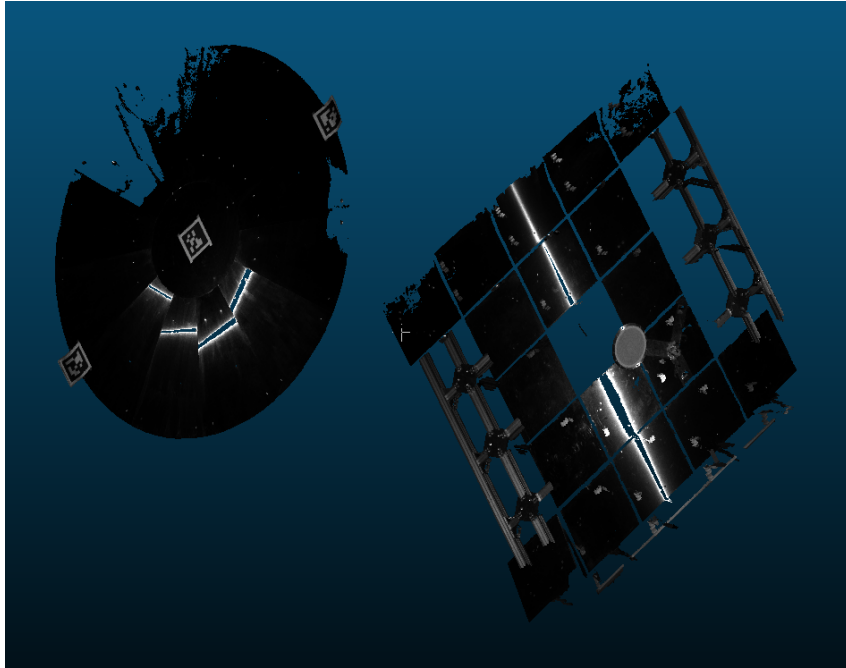

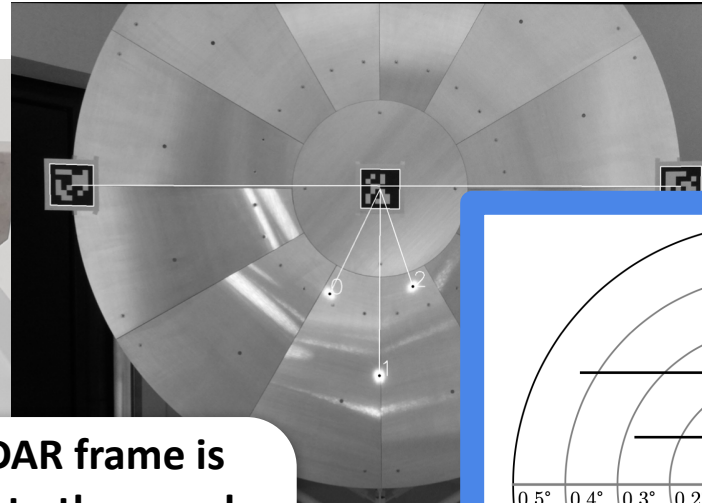
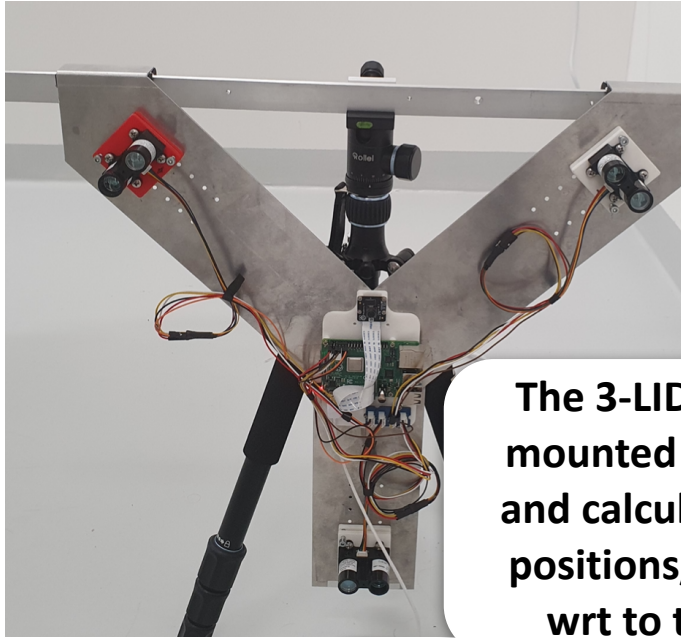

The 3-LIDAR frame is mounted to the panel and calculated the absolute positions/tilted angle wrt to the mirror.

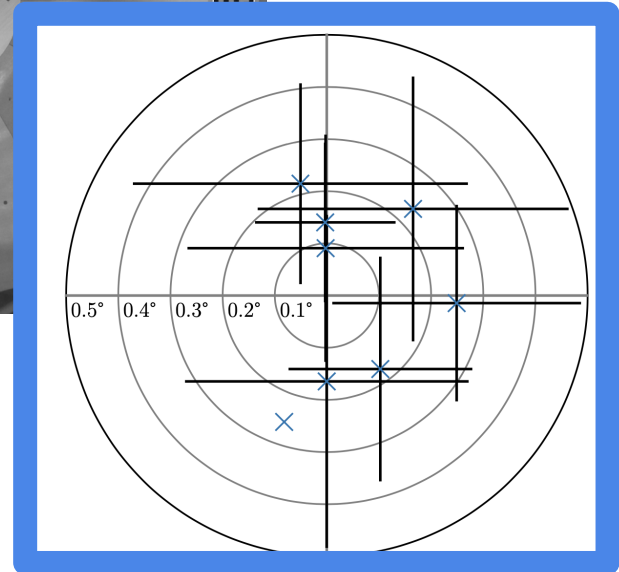

Setup 1: De-Broglie Wavelength Coherence

- De-Broglie wavelength: $\lambda = \frac{h}{mv}$
- Wave vector perpendicular to panel \rightarrow always coherent.
- Wave vector parallel to panel.
 \rightarrow highly depending on wavelength
- Short wavelength limit: phase varies completely over the experiment size.
- Example: 12 GHz, $\lambda_{DB} = 25m$

$$\phi_{max} = 0.38$$

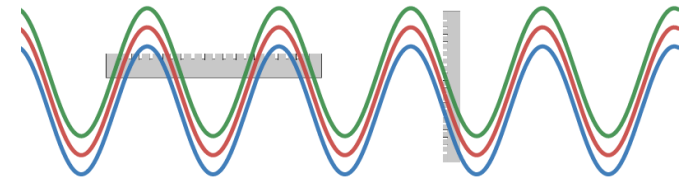

short wavelength limit

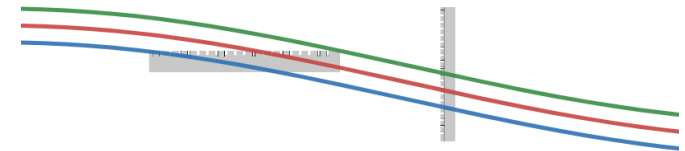

long wavelength limit

Coherence Study

- J_a is modified with an additional phase factor: $J_a \exp(i\phi)$
- Phase ϕ can vary between $(0, 2\pi)$ and depends on the frequency and the dimension of the panels
- Negligible effect to the BRASS-p

